



# SURFACE VEHICLE RECOMMENDED PRACTICE

J2284™-5

SEP2016

Issued

2016-09

High-Speed CAN (HSC) for Vehicle Applications at 500 kbps with CAN FD Data  
at 5 Mbps

## RATIONALE

Facilitate usage of the CAN with Flexible Data Rate (CAN FD) message format for data communication between a vehicle and off board tools.

## FOREWORD

The objective of SAE J2284-5 is to define a level of standardization in the implementation of a 500 kbps arbitration bus with CAN FD Data at 5 Mbps for a point to point connection between a vehicle and off board tools using the Controller Area Network (CAN) protocol. The goal is to achieve a standard Electronic Control Unit (ECU) Physical Layer, Data Link Layer, and Media Design Criteria which will allow ECU and tool manufacturers to satisfy the needs of multiple end users with minimum modification to a basic design. Likewise, end users will benefit in lower ECU cost achieved from the high volumes of the basic design.

## TABLE OF CONTENTS

1.	SCOPE.....	3
2.	REFERENCES.....	4
2.1	Applicable Documents.....	4
2.1.1	SAE Publications.....	4
2.1.2	ISO Publications.....	4
2.1.3	Other Publications.....	5
3.	DEFINITIONS.....	5
4.	ACRONYMS.....	9
5.	SYSTEM LEVEL ATTRIBUTES OF THE NETWORK.....	10
5.1	Message Format.....	10
5.2	Communication Rate.....	10
5.3	Basic Communication Network Parameters.....	10
5.4	Topology and Termination.....	11
5.4.1	Single On-Board ECU Configuration.....	11
5.4.2	Additional Requirements.....	12
5.5	Unshielded Media.....	12
5.6	Communication/Survivability Under Faulted Conditions.....	13

SAE Technical Standards Board Rules provide that: "This report is published by SAE to advance the state of technical and engineering sciences. The use of this report is entirely voluntary, and its applicability and suitability for any particular use, including any patent infringement arising therefrom, is the sole responsibility of the user."

SAE reviews each technical report at least every five years at which time it may be revised, reaffirmed, stabilized, or cancelled. SAE invites your written comments and suggestions.

Copyright © 2016 SAE International

All rights reserved. No part of this publication may be reproduced, stored in a retrieval system or transmitted, in any form or by any means, electronic, mechanical, photocopying, recording, or otherwise, without the prior written permission of SAE.

TO PLACE A DOCUMENT ORDER: Tel: 877-606-7323 (inside USA and Canada)  
Tel: +1 724-776-4970 (outside USA)  
Fax: 724-776-0790  
Email: CustomerService@sae.org  
http://www.sae.org

SAE WEB ADDRESS:

**SAE values your input. To provide feedback  
on this Technical Report, please visit  
[http://www.sae.org/technical/standards/J2284/5\\_201609](http://www.sae.org/technical/standards/J2284/5_201609)**

5.7	EMC Criteria.....	14
5.8	Off-Board Tool Requirements .....	14
5.8.1	Off-Board Tool Capacitive Load.....	14
5.8.2	Off-Board Tool Propagation Delay.....	15
5.9	Off-Board Tool Cable Requirements.....	15
5.9.1	Cable Length.....	15
5.9.2	Cable Propagation Delay .....	15
5.9.3	Cable Configuration .....	16
6.	ECU REQUIREMENTS.....	16
6.1	Absolute Maximum Ratings .....	16
6.1.1	Direct Voltage Connection .....	16
6.1.2	Unpowered Storage Temperature .....	17
6.2	DC Operating Parameters.....	17
6.2.1	DC Parameters – Output Behavior - Recessive Bus State - Bus Disconnected .....	18
6.2.2	DC Parameters – Output Behavior - Dominant Bus State - Bus Disconnected .....	18
6.2.3	DC Parameters – Output Behavior – ECU unpowered/Bus Bias Off - Bus Disconnected .....	19
6.2.4	DC Parameters – Input Behavior – Bus Disconnected.....	19
6.2.5	AC Parameters – Output Behavior – Bus Disconnected .....	19
6.2.6	DC Parameters - Recessive Bus State – Normal Operating Mode - Bus Connected .....	19
6.2.7	DC Parameters - Dominant Bus State – Normal Operating Mode - Bus Connected .....	20
6.3	ECU Internal Capacitance .....	20
6.4	Termination .....	20
6.5	Connector Parameters.....	21
6.6	Bit Timing Requirements.....	21
6.6.1	Nominal Bit Time ( $t_{BIT}$ ).....	21
6.6.2	Data Bit Time .....	21
6.6.3	Data Sample Mode .....	21
6.6.4	CAN Bit Timing and Register Settings.....	21
6.6.5	Transmitter Delay Compensation .....	23
6.7	Message Transmission and Reception.....	23
6.8	ECU Configuration Requirements.....	23
6.9	ElectroMagnetic Compatibility (EMC) .....	24
7.	CAN COMPONENT REQUIREMENTS.....	24
7.1	Bus Transceiver Requirements.....	24
7.2	Bus Controller Requirements.....	28
7.3	Microcontroller Requirements and Preferences .....	30
8.	NOTES.....	30
8.1	Revision Indicator.....	30
Figure 1	Single on-board ECU configuration A.....	11
Figure 2	Single on-board ECU configuration B.....	12
Figure 3	Off-board tool parameters.....	14
Table 1	Basic communication network parameters .....	10
Table 2	Network topology requirements .....	12
Table 3	Physical media parameters for unshielded twisted pair.....	13
Table 4	Fault Behavior .....	13
Table 5	Off-board tool capacitive load (without cable load).....	14
Table 6	Off-board tool propagation delay (loop delay without cable delay).....	15
Table 7	Off-board tool cable length.....	15
Table 8	Off-board tool cable propagation delay (one-way delay without off-board tool delay) .....	15
Table 9	ECU Maximum Bus Wire Voltage - No damage to ECU (12 V system).....	16

Table 10	ECU Operating Parameters – CAN Data Communication.....	17
Table 11	ECU DC Parameters – Output Behavior Recessive - Bus Disconnected .....	18
Table 12	ECU DC Parameters – Output Behavior Dominant - Bus Disconnected.....	18
Table 13	ECU DC Parameters – Input Behavior – ECU unpowered/Bus bias off – Bus Disconnected.....	19
Table 14	ECU DC Parameters – Input Behavior - Bus Disconnected .....	19
Table 15	ECU AC Parameters – Output Behavior - Bus Disconnected .....	19
Table 16	ECU DC Parameters – Recessive Bus State – Bus Connected .....	19
Table 17	ECU DC Parameters – Dominant Bus State – Bus Connected.....	20
Table 18	ECU Internal Capacitance – ECU disconnected .....	20
Table 19	ECU Termination Characteristics.....	20
Table 20	ECU Connector Characteristics .....	21
Table 21	ECU CAN bit timing – min/max.....	22
Table 22	ECU CAN register settings for first standard time quanta .....	22
Table 23	ECU CAN register settings for second standard time quanta .....	22
Table 24	ECU – Basic CAN Interface Functional Requirements.....	23
Table 25	Bus Transceiver – Basic Requirements.....	25
Table 26	Bus Transceiver – Maximum Bus Pin Voltage - No damage to transceiver (12 V system).....	25
Table 27	Bus Transceiver – General Operating Conditions .....	26
Table 28	Bus Transceiver – DC Parameters – Output Behavior – Recessive/Off State.....	26
Table 29	Bus Transceiver – DC Parameters – Output Behavior – Dominant State .....	27
Table 30	Bus Transceiver – DC Parameters – Input Behavior/Threshold – Sleep Mode Absent .....	27
Table 31	Bus Transceiver – DC Parameters – Input Behavior/Threshold – Sleep Mode Present.....	27
Table 32	Bus Transceiver – AC Parameters .....	28
Table 33	CAN Controller – Basic Requirements.....	29

## 1. SCOPE

This SAE Recommended Practice will define the Physical Layer and portions of the Data Link Layer of the Open Systems Interconnection model (ISO 7498) for a 500 kbps arbitration bus with CAN FD Data at 5 Mbps High-Speed CAN (HSC) protocol implementation. Both ECU and media design requirements for networks will be specified. Requirements will primarily address the CAN physical layer implementation.

Requirements will focus on a minimum standard level of performance from the High-Speed CAN (HSC) implementation. All ECUs and media shall be designed to meet certain component level requirements in order to ensure the HSC implementation system level performance at 500 kbps arbitration bus with CAN FD Data at 5 Mbps. The minimum performance level shall be specified by system level performance requirements or characteristics described in detail in Section 6 of this document.

This document is designed such that if the Electronic Control Unit (ECU) requirements defined in Section 6 are met, then the system level attributes should be obtainable.

This document will address only requirements which may be tested at the ECU and media level. No requirements which apply to the testing of the HSC implementation as integrated into a vehicle are contained in this document. However, compliance with all ECU and media requirements will increase the possibility of communication compatibility between separately procured components and will greatly simplify the task of successfully integrating a HSC communication system in a vehicle.

## 2. REFERENCES

This specification takes precedence over all conflicts in the documents cited in this section.

### 2.1 Applicable Documents

The following publications form a part of this specification to the extent specified herein. Unless otherwise indicated, the latest issue of SAE publications shall apply.

#### 2.1.1 SAE Publications

Available from SAE International, 400 Commonwealth Drive, Warrendale, PA 15096-0001, Tel: 877-606-7323 (inside USA and Canada) or +1 724-776-4970 (outside USA), [www.sae.org](http://www.sae.org).

- SAE J551-15 Vehicle Electromagnetic Immunity – Electrostatic Discharge (ESD)
- SAE J1213-1 Glossary of Vehicle Networks for Multiplexing and Data Communications
- SAE J1930 Electrical/Electronic Systems Diagnostic Terms, Definitions, Abbreviations, and Acronyms
- SAE J1962 Diagnostic Connector
- SAE J2190 Enhanced E/E Diagnostic Test Modes
- SAE J2962-2 Communication Transceivers Qualification Requirements – CAN
- SAE 970295 CAN Bit Timing Requirements

#### 2.1.2 ISO Publications

Copies of these documents are available online at <http://webstore.ansi.org/>

- ISO 7498 Data processing systems – Open systems interconnection standard reference model
- ISO 7637-1 Road vehicles – Electrical disturbance by conduction and coupling
- ISO 10605 Road vehicles – Test methods for electrical disturbances from electrostatic discharge
- ISO 11451-2 Road vehicles – Vehicle test methods for electrical disturbances from narrowband radiated electromagnetic energy - Part 2: Off-vehicle radiation sources
- ISO 11452-4 Road vehicles – Component test methods for electrical disturbances from narrowband radiated electromagnetic energy – Part 4: Harness excitation methods
- ISO 11898-1 :2015(E) Road vehicles – Interchange of digital information – Controller area network (CAN), Part 1: Data link layer and physical signaling
- ISO 11898-2 :2016(E) Road vehicles – Interchange of digital information – Controller area network (CAN), Part 2: High-speed medium access unit
- ISO 14229 Road vehicles – Diagnostic systems – Specification of diagnostic services
- ISO 26262 Road vehicles – Functional safety

### 2.1.3 Other Publications

CISPR 25 Limits and Methods of Measurement of Radio Disturbance Characteristics for the Protection of Receivers Used On-Board Vehicles

AUTOSAR Release 4.2.2 [www.autosar.org](http://www.autosar.org)

## 3. DEFINITIONS

The definitions provided in SAE J1213-1 apply to this document. Additional or modified definitions, acronyms, and abbreviations included in this document or relevant to the communication of information in a vehicle are catalogued in this section.

### 3.1 ARBITRATION BIT TIME

See Nominal Bit Time.

### 3.2 BUS TERMINATION

Elements in a subnet (per default two) that implement presence of a defined resistance between CAN\_H and CAN\_L.

### 3.3 CAN\_H

The CAN\_H bus wire is fixed to a mean voltage level during the recessive state and is driven in a positive voltage direction during the dominant bit state.

### 3.4 CAN\_L

The CAN\_L bus wire is fixed to a mean voltage level during the recessive state and is driven in a negative voltage direction during the dominant bit state.

### 3.5 CAN ACTIVITY FILTER TIME

Duration for which the bus needs to be continuously in the same state to enable the signal to pass the bus wake-up filter.

### 3.6 CAN BUS

Subnet where a number of ECUs communicate via a two-wire link (CAN\_H, CAN\_L) and where the Controller Area Network protocol is used as data link layer (DLL).

### 3.7 CAN IDENTIFIER

Bit pattern of 11 bits or 29 bits, located at the beginning of a message that denotes message content and also reflects message priority.

### 3.8 CLASSICAL CAN MESSAGE

Bus message according to ISO 11898:1993/Amd.1:1995(E). Bus message according to ISO 11898-1:2015(E) where the FDF bit is dominant, also known as CAN 2.0.

### 3.9 CAN FD MESSAGE

Bus message according to ISO 11898-1:2015(E) where the FDF bit is recessive. A CAN FD message typically employs different bit rates in the data field and in the arbitration field.

### 3.10 DATA BIT TIME

Length of a single bit in those parts of CAN FD messages where a dedicated separately configurable data bit time is used. The data bit time is not used anywhere in Classical CAN messages and is not used in those CAN FD messages where the BRS bit is dominant.

### 3.11 DATA LINK LAYER

Provides the reliable transfer of information across the Physical Layer. This includes message qualification and error control.

### 3.12 DATA SAMPLE POINT ( $t_{\text{SAMPLE}}$ )

The sample point is the time within the bit period at which the single bit sample captures the state of the bus. The programmable bit sample point is located between  $t_{\text{SEG1}}$  and  $t_{\text{SEG2}}$ . Equation 1 shows the relationship of  $t_{\text{SAMPLE}}$  to  $t_{\text{SEG2}}$ :

$$t_{\text{SAMPLE}} = t_{\text{BIT}} - t_{\text{SEG2}} \quad (\text{Eq. 1})$$

### 3.13 DIAGNOSTIC CONNECTOR

Provides the electrical connection between Off-Board and On-Board ECUs. For some vehicles, the diagnostic connector is the SAE J1962 connector.

### 3.14 DISABLING OF DLC MATCHING

When this functionality is supported and active, then the bus transceiver will not compare message data length code (DLC) values as to whether or not they match to configured DLC values when scanning messages for presence of valid wake-up requests.

### 3.15 DOMINANT STATE

The dominant state is represented by a differential voltage greater than a minimum threshold between the CAN\_L and CAN\_H bus wires. The dominant state overwrites the recessive state and represents a logic "0" bit value.

### 3.16 ELECTRONIC CONTROL UNIT (ECU)

An On- or Off-vehicle electronic assembly from which CAN SAE J2284-5 messages may be sent and/or received.

### 3.17 ECU Delay ( $t_{\text{ECU}}$ )

An ECU's loop delay includes the following four delays:

- a. Transmitter Propagation Delay ( $t_{\text{TX}}$ , this includes device delay and slew)
- b. Receiver Propagation Delay ( $t_{\text{RX}}$ )
- c. Receiver Logic Delay ( $t_{\text{LOGIC}}$ )
- d. Common Mode Choke ( $t_{\text{CHK}}$ , optional, Includes both Tx and Rx choke delays)

$$t_{\text{ECU}} = (t_{\text{TX}} + t_{\text{RX}} + t_{\text{LOGIC}} + t_{\text{CHK}}) \quad (\text{Eq. 2})$$

### 3.18 FD\_Receive / FD\_Transmit

Status flags indicating whether the bus controller employs CAN FD data bit timing presently.

### 3.19 HANDLE

Hardware object label of one or multiple LLC frames (LPDU). Identifies hardware element used for transaction. Used to facilitate cancellation of pending message transmission requests.

### 3.20 MEDIA

The physical entity which conveys the electrical (or equivalent means of communication) transmission between ECUs on the network (e.g., unshielded twisted pair wires). Media is defined as all elements between the connector pins of the communicating ECUs through which the signals pass.

### 3.21 MEDIA DELAY ( $t_{BUS}$ )

Media delay is defined as the time required for a signal to pass through the media at the longest specified distance (see Table 1 in 5.3, Table 2 in 5.4, and Table 3 in 5.5).

### 3.22 MUST

The word "**Must**" is used to indicate that a binding requirement exists on components or devices which are outside the scope of this specification.

### 3.23 NOMINAL BIT TIME

Length of a single bit in Classical CAN messages. Length of a single bit in CAN FD messages except where data bit timing applies. Also known as arbitration bit time.

### 3.24 PCS STATUS

Indicates what logical level is presently being received or transmitted and whether or not CAN FD data bit timing applies presently. For details see ISO 11898-1 :2015(E).

### 3.25 PHYSICAL LAYER

Concerns the transmission of an unstructured bit stream over physical media: deals with the mechanical, electrical, functional, and procedural characteristics to access the physical media.

### 3.26 PROTOCOL

Formal set of conventions or rules for the exchange of information between ECUs. This includes the specification of frame administration, frame transfer, and physical layer.

### 3.27 RADIATED EMISSIONS

Radiated Emissions consists of energy that emanate from the CAN bus wires. Electric field strength in  $dB\mu V/m$  is the typical measure of radiated emissions.

### 3.28 RADIATED IMMUNITY

A property that ensures that the CAN bus wires will not suffer degraded functional operation within its intended electromagnetic environment.

### 3.29 RECESSIVE STATE

The recessive state is represented by an inactive state differential voltage that is approximately 0. The recessive state represents a logic “1” bit value.

### 3.30 PROPAGATION DELAY ( $t_{PROP}$ )

Part of bit cell that serves compensation of data signal delay times in a network. Because CAN is an arbitrating protocol, the propagation delay must take into account the time required for a signal to make a complete round trip from one CAN controller to another and back. This translates to Equation 3 or 4.

$$t_{PROP} = 2(t_{TX} + t_{RX} + t_{LOGIC} + t_{CHK} + t_{BUS}) \quad (\text{Eq. 3})$$

or

$$t_{PROP} = 2(t_{ECU} + t_{BUS}) \quad (\text{Eq. 4})$$

### 3.31 SECONDARY SAMPLE POINT (SSP)

Sample point that applies to data bit timing in CAN FD (BRS = recessive) messages when the transmitter delay compensation functionality is configured to be enabled/active. The transmitting bus controller automatically determines/adapts/delays the location of the sample point based on observed data signal delay of the particular transmitter implementation, unless transmitter delay compensation disabled.

### 3.32 SELECTIVE WAKE-UP BUS TRANSCEIVER

Not applicable for this 5 Mbps data bit rate network which is defined as a two node network.

### 3.33 SHALL

The word “**Shall**” is to be used in the following ways:

- a. To state a binding requirement on the CAN interfaces which comprise the ECU, which is verifiable by external manipulation and/or observation of an input or output.
- b. To state a binding requirement upon an ECU that is verifiable through a review of the document.

### 3.34 SHOULD

The word “**Should**” is used to denote a preference or desired conformance.

### 3.35 SPLIT BUS TERMINATION

Bus termination where the resistance between CAN\_H and CAN\_L is split into two parts of equal value. Resistance center tap connected to ground via a capacitor unless otherwise specified.

### 3.36 SYNCHRONIZATION JUMP WIDTH ( $t_{SJW}$ )

This time interval is the maximum amount of time by which  $t_{SEG1}$  may be lengthened or  $t_{SEG2}$  shortened to compensate for synchronization differences between ECUs on the CAN network. This is accomplished automatically in the CAN controller as a basic part of the protocol. However, the amount of skew tolerated is adjustable by software programming.

### 3.37 SYNCHRONIZATION SEGMENT ( $t_{SYNC\_SEG}$ )

This time interval is used to synchronize all ECUs on the bus. If all ECUs are fully synchronized, then all bit edges occur in this interval, which has a fixed period of one Time Quantum.



### 3.38 TIME QUANTUM ( $t_Q$ )

This is the basic unit of time for bit timing. This time is derived from the microcontroller's oscillator clock and is programmable based on the CAN controller's divide register values.

### 3.39 TRANSMITTER DELAY COMPENSATION (TDC)

For data bit timing in CAN FD messages the transmitting CAN controller automatically will compensate the signal delay caused by the ECU-internal transmitter implementation, unless TDC functionality disabled. Functionality inactive for arbitration bit timing in CAN FD messages and generally inactive in classical CAN messages. For details see ISO 11898-1 :2015(E).

### 3.40 TSEG1 ( $t_{SEG1}$ )

This time interval is used to compensate for positive phase errors in synchronization between ECUs on the network. If an edge occurs during this interval,  $t_{SEG1}$  is lengthened to compensate for synchronization differences with other ECUs on the CAN network.  $T_{SEG1}$  is equivalent to the combination of the Prop\_Seg and Phase\_Seg1 parts of the bit period defined in ISO 11898-1 :2015(E).

### 3.41 TSEG2 ( $t_{SEG2}$ )

This time interval is used to compensate for negative phase errors in synchronization between ECUs on the network. If an edge occurs during this interval,  $t_{SEG2}$  is shortened to compensate for synchronization differences with other ECUs on the CAN network.  $T_{SEG2}$  is equivalent to the Phase\_Seg2 part of the bit period defined in ISO 11898-1 :2015(E).

### 3.42 WILL

The word "**Will**" is used to state an immutable law of physics.

## 4. ACRONYMS

ASIL	Automotive Safety Integrity Level
BRS	Bit Rate Switch
CAN	Controller Area Network
CAN FD	CAN with Flexible Data Rate
CAN ID	CAN Identifier
DLC	Data Length Code
ECU	Electronic Control Unit
EMC	ElectroMagnetic Compatibility
ESD	Electrostatic Discharge
ESI	Error Status Indicator
FD	Flexible Data Rate (message format)
FDF	Flexible Data Rate Format
HSC	High-Speed CAN
ISO	International Standardization Organization
kbps	KiloBits Per Second
LLC	Logical Link Control (layer)
LPDU	LLC Protocol Data Unit (frame)
MAC	Media Access Control (layer)
Mbps	MegaBits Per Second
NOP	Non-operating (only survival is demanded)
OBD II	On Board Diagnostics (level 2)
PCS	Physical Coding Sub-layer
$R_L$	Resistive Load between CAN_H and CAN_L
$R_Z$	Bus Termination Resistance (125 $\Omega$ nominal)
SAE	SAE International
V <sub>batt</sub>	Power supply for the ECUs present in a communication network (12V nominal)
V <sub>Diff</sub>	Differential bus voltage ( $V_{Diff} = V_{CAN\_H} - V_{CAN\_L}$ )

## 5. SYSTEM LEVEL ATTRIBUTES OF THE NETWORK

This section describes System Level performance attributes of a 500 kbps HSC network for automotive vehicle applications. It is up to the particular system owner to ensure that network level limits in this chapter are met. This HSC network is based on ISO 11898-1 and ISO 11898-2 releases stated in 2.1.2 with the modifications and additions described as follows:

### 5.1 Message Format

All ECU CAN interfaces shall, at a minimum, conform to the ISO 11898-1 (Road vehicles — Controller area network (CAN) — Part 1: Data link layer and physical signaling) and ISO 11898-2 (Road vehicles — Controller area network (CAN) — Part 2: High-speed medium access unit), releases as stated in 2.1.2. For details, see sections 6 and 7 later in this document.

All ECUs intended for use in a subnet according to J2284-5 shall, at a minimum, be passive to CAN FD format frames, meaning shall not send error frames against and shall not increase ECU-internal error counters when syntactically correct CAN FD format frames with bit rates stated below in this document are present.

All ECUs that utilize the 11-bit base frame identifier shall be, at a minimum, passive to the 29-bit extended frame identifier. All SAE J2284-5 compliant ECUs that support OBD II requirements shall fully support a 29-bit extended frame identifier.

The encoding of the 11-bit identifier field shall be vehicle manufacturer specific. The CAN requirement (see CAN 2.0 protocol specification and superseded ISO 11898-1 CAN documents) specifying that the 7 most significant bits (ID-28 – ID-22) must not be all recessive shall not be enforced in hardware by SAE J2284-5. CAN protocol implementations shall be capable to transmit and receive all identifier bit combinations without any restrictions.

The maximum message frame shall consist of the CAN identifier (CAN ID) plus 64 data bytes.

### 5.2 Communication Rate

Classical CAN messages and CAN FD messages where the bit BRS is dominant shall utilize a single communication rate of 500 kbps. CAN FD messages where the bit BRS is recessive shall utilize a communication rate of 500 kbps for arbitration, end of frame fields, and syntax error notifications and shall utilize 5 Mbps for message data fields (i.e. from sample point of BRS bit to sample point of CRC Delimiter bit).

### 5.3 Basic Communication Network Parameters

The intent of this standard is to specify data communication for networks with these properties.

**Table 1 – Basic communication network parameters**

Parameter	Symbol	Minimum	Maximum	Units	Conditions
Number of nodes (bus interfaces)	$N_{nd}$	2	2	--	(1)
Data communication operating ground offset voltage	$V_{GND-OP}$		2	Volts	(2)
Network level overall differential resistive load	$R_L$	50	65	$\Omega$	(3)
(Wiring) Resistance between any two bus transceiver CAN_H to CAN_H (CAN_L to CAN_L) pins	$R_w$		9	$\Omega$	(4)
Maximum propagation time between any two ECUs	$t_{BUS}$		100	ns	(5)
1. Directly connected within a particular subnet. 2. Between any two ECUs in a subnet. 3. Between CAN_H and CAN_L. 4. Intends to reflect the bus wiring resistive behavior. 5. Includes one way wiring delay and node loading delay.					

## 5.4 Topology and Termination

The wiring topology of this network supports a linear structure, including daisy-chain configurations, and including bus cable stubs. The bus shall be terminated in a way so that the network level overall resistive load between the CAN\_H and CAN\_L wires will be consistent to line item  $R_L$  in Table 1. Termination shall be located at each end of the bus. Termination units shall establish a defined resistance between the CAN\_H and CAN\_L wires. Two bus termination units shall be present in a subnet. Each of two termination units shall meet the requirements stated in 6.4.

### 5.4.1 Single On-Board ECU Configuration

The topology requirements for a network containing a single ECU On-Board the vehicle and a single ECU Off-Board the vehicle (e.g., an OBD Scan Tool) are specified in Figures 1 and 2 and in Table 2. Note, presence of bus termination is needed, otherwise the network will not work.

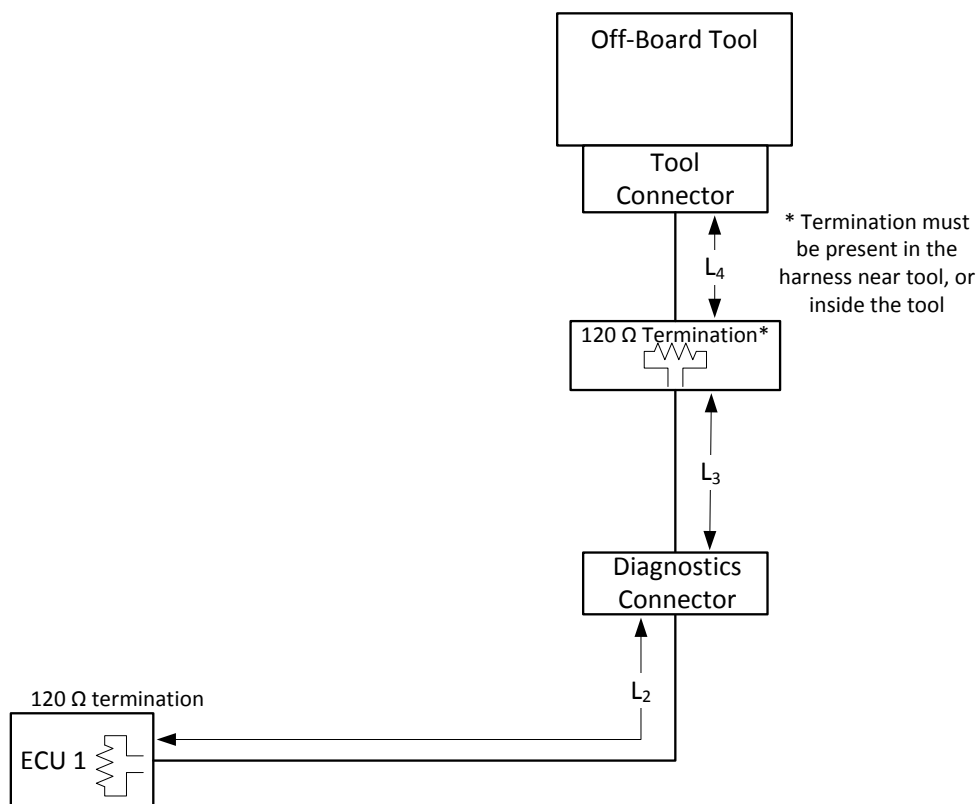

**Figure 1 – Single on-board ECU configuration A**

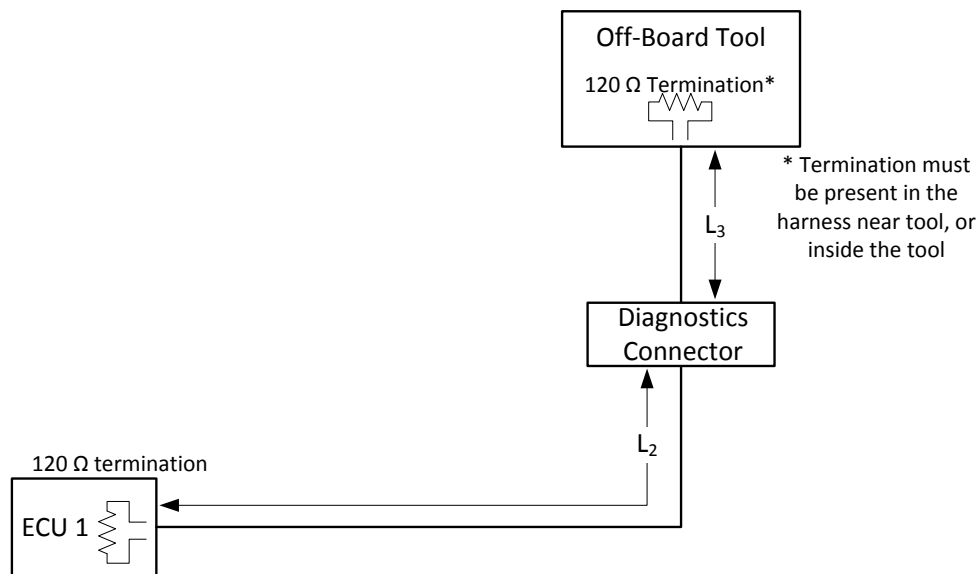

**Figure 2 – Single on-board ECU configuration B**

**Table 2 – Network topology requirements**

Parameter	Symbol	Minimum	Nominal	Maximum	Unit	Comments
In-Vehicle Cable Stub Length	$L_2$	0.1		5	meter	Cable length between the Diagnostic Connector and On-Board ECU shall be limited to said value
Off-Board Cable Stub Length	$L_3$	0		5	meter	Cable length between the Diagnostic Connector and Off-Board tool/node shall be limited to said value
Termination Distance from Tool	$L_4$	0		0.1	meter	Cable length between tool connector and termination resistance

The purpose of the ECU minimum distance requirement is to ensure that wires are twisted in-between ECUs and/or splices. This does not apply to multiple nodes in the same ECU.

For topology and termination requirements for tools see 5.8.

#### 5.4.2 Additional Requirements

- There shall be a single bus termination in the On-Board ECU. Acceptable implementations are a split bus termination.
- There shall be a bus termination in the Off-Board tool or in the Off-Board bus wiring harness, close to the Off-Board tool. Acceptable implementations are a single 120  $\Omega$  terminator or alternatively a split bus termination. Non-terminating ECUs can be optional connections.

#### 5.5 Unshielded Media

The network shall operate using a shielded or unshielded twisted wire pair. The bus cable details are specified in Table 3.

(See Table 3.)

**Table 3 – Physical media parameters for unshielded twisted pair**

Symbol	Minimum	Nominal	Maximum	Units	Conditions
Z	90	115	140	$\Omega$	f = 1 MHz
R <sub>LENGTH</sub>			120	m $\Omega$ /meter	Single conductor
t <sub>DELAY</sub>			5.3	ns/meter	Wire only
RATE <sub>TWIST</sub>	33	40		Twists/meter	360 degrees

Parameter values in Table 3 apply over operating conditions and product lifetime, unless otherwise indicated.

#### 5.6 Communication/Survivability Under Faulted Conditions

No damage to ECUs when one, and only one at a time, of the below listed failures becomes present. (See Table 4.)

**Table 4 - Fault Behavior**

Description of Failure	Communication Behavior
ECU loss of power or ground (includes low battery condition)	Data communication is not possible.
CPU goes into reset, while its physical layer and IC is still powered	Data communication is not possible.
CAN_H wire open	Data communication is not required.
CAN_L wire open	Data communication is not required.
CAN_H shorted to battery	Data communication may be possible with reduced signal to noise ratio. Data communication is not required when V <sub>batt</sub> is greater than the maximum allowed common mode voltage.
CAN_L shorted to battery	Data communication is not possible.
CAN_H shorted to ground	Data communication is not possible.
CAN_L shorted to ground	Data communication may be possible with reduced signal to noise ratio.
CAN_H shorted to CAN_L	Data communication is not possible.
Bus is stuck in a dominant state	Data communication is not possible.
CAN_H and CAN_L concurrently shorted to ground	Data communication is not possible.
CAN_H and CAN_L concurrently shorted to battery	Data communication is not possible.
CAN_H ECU terminal connected to CAN_L wire and CAN_L ECU terminal connected to CAN_H wire	Data communication is not required with the ECU incorrectly connected to the bus.
Loss of one termination	Depending on bus wire length, and bit timing margin, data communication may be possible with reduced signal to noise ratio.

Where Table 4 suggests “data communication is not required” and the application allows, then the ECU may enter low-power mode until there is a valid wake-up condition.

## 5.7 EMC Criteria

The ECU EMC requirements as specified in 6.9 are intended to satisfy vehicle level EMC compliance when tested in accordance with CISPR 25, ISO 11451-2, and ISO 10605.

## 5.8 Off-Board Tool Requirements

The SAE J2284-5 bus shall be wired to the Diagnostic Connector, and the following requirements apply:

- Unless otherwise indicated, the Off-Board Tool shall meet the requirements for On-Board ECUs stated in Section 6 in this document.
- The Off-Board Tool shall be one of the two allowable bus nodes.
- The Off-Board Tool shall be a terminated node on the CAN network.
- The distance between the Diagnostic Connector and any On-Board (ECU) shall be limited to  $L_3$  in Table 2.

### 5.8.1 Off-Board Tool Capacitive Load

See Figure 3 and Table 5.

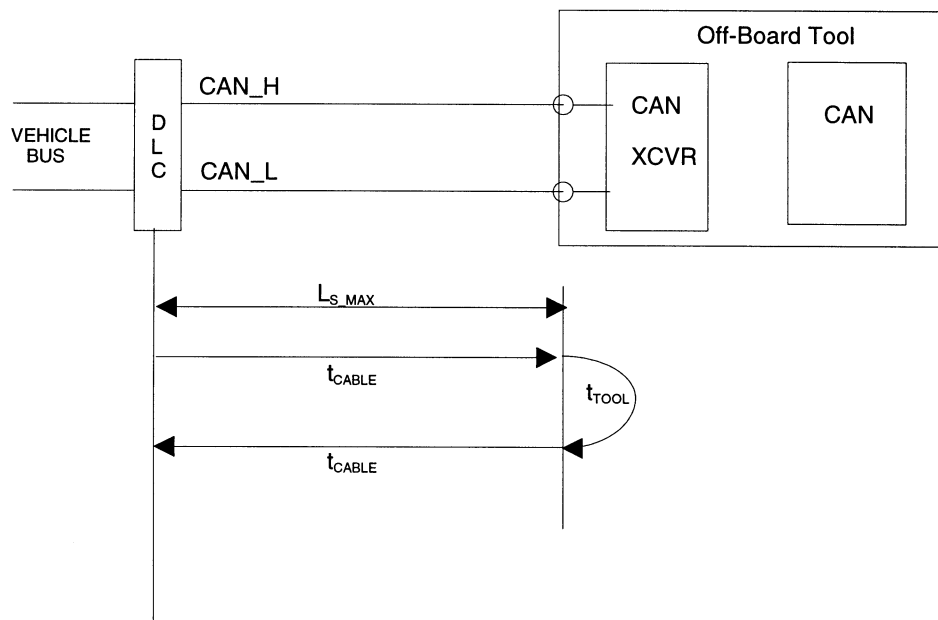

**Figure 3 - Off-board tool parameters**

The specified values for the Off-Board Tool capacitive load do not include the capacitive load of the Off-Board Tool cable.

**Table 5 - Off-board tool capacitive load (without cable load)**

Term	Min	Nominal	Max	Remark
$C_{diff}$	—	—	50 pF	CAN_H to CAN_L
$C_{Can\_H}, C_{CAN\_L}$	—	—	100 pF	CAN_H/CAN_L to ground potential

### 5.8.2 Off-Board Tool Propagation Delay

The value given in Table 6 for the Off-Board Tool propagation delay does not include the cable propagation delay. This requirement is based upon the most critical timing when operating at the baud rate of 500 kbps. The Off-Board Tool propagation delay (loop delay) includes the following four delays:

- a. Transmitter propagation delay ( $t_{TX}$ ), this includes device delay and slew.
- b. Receiver propagation delay ( $t_{RX}$ )
- c. Receiver logic delay

$$t_{TOOL} = t_{TX} + t_{RX} + t_{LOGIC} + t_{CHK} \quad (\text{Eq. 5})$$

**Table 6 - Off-board tool propagation delay (loop delay without cable delay)**

Term	Min	Nominal	Max	Remark
$t_{TOOL}$	—	—	340 ns	Loop Delay of Off-Board Tool

### 5.9 Off-Board Tool Cable Requirements

The Off-Board Tool cable shall provide interconnection between the vehicle DLC and the CAN interface of the Off-Board Tool (see 6.8).

#### 5.9.1 Cable Length

The Off-Board Tool cable length is defined to be the length of the cable between the DLC and the Off-Board Tool CAN interface. See Table 7.

**Table 7 - Off-board tool cable length**

Term	Min.	Nominal	Max	Remark
$L_{S\_MAX}$	—	—	5 m	Off-Board Tool cable length

#### 5.9.2 Cable Propagation Delay

The cable propagation delay is defined as a one-way delay. See Table 8.

**Table 8 - Off-board tool cable propagation delay (one-way delay without off-board tool delay)**

Term	Min.	Nominal	Max	Remark
$t_{CABLE}$	—	—	30 ns	Off-Board Tool cable delay

### 5.9.3 Cable Configuration

The following requirements apply to the Off-Board Tool cable:

- a. No other wires shall be twisted with either CAN conductor CAN\_H or CAN\_L.
- b. The CAN\_H and CAN\_L conductors shall be of the same length, traverse the same path for the entire distance.
- c. CAN\_H and CAN\_L conductors shall not be included in any wire bundle containing radiating wires which induce more than 0.5 V differential signal between the CAN\_H and CAN\_L conductors.
- d. The Off-Board cable may be shielded. If it is shielded, the shield shall be grounded at one end only.
- e. The Off-Board Tool cable shall meet the requirements for twisting and characteristic impedance, see 5.5.

## 6. ECU REQUIREMENTS

This section describes the electrical requirements for an ECU on an HSC network. The requirements described are designed to support the design goals described in Section 5, System Level Attributes. Parameter values in this specification apply over operating conditions and product lifetime, unless otherwise indicated. Parameter values in this section are measured at the connector pins of the particular ECU, unless otherwise indicated.

### 6.1 Absolute Maximum Ratings

Network related electrical components within the ECU shall not suffer permanent damage. Ability to perform network communications under these conditions is out of scope (not required).

#### 6.1.1 Direct Voltage Connection

The table below states requirements on ECUs intended for use in networks powered with a voltage of 12V nominal. Abbreviation NOP stands for non-operating (survival). (See Table 9.)

**Table 9 – ECU Maximum Bus Wire Voltage - No damage to ECU (12 V system)**

Symbol	Minimum	Maximum	Units	Conditions
$V_{CAN\_H\_ECU-NOP}$	-13.0	27.0	Volts	All ECUs, t = 120 s
$V_{CAN\_L\_ECU-NOP}$	-13.0	27.0	Volts	All ECUs, t = 120 s
$V_{Diff\_ECU-NOP1}$	-5.0	7.0	Volts	All ECUs, t = 120 s
$V_{Diff\_ECU-NOP2}$	n/a	10.0	Volts	All ECUs: t = 10 ms Non-terminating ECUs: t = 120 s

Table 5 reflects maximum and minimum voltages which shall not cause damage when connected to CAN bus outputs of an ECU. These limits apply for when an ECU is attempting to transmit message, receive messages, and for bus idle. These limits also apply to all operating modes of an ECU including regular communication, sleep, scanning messages for presence of valid wake-up request, and unpowered ( $V_{batt}$  disconnected,  $V_{batt} = 0V$ ) conditions. Successful transfer of messages between bus nodes is not expected when stated minimum or maximum voltages are present ( $V_{Diff} = V_{CAN\_H} - V_{CAN\_L}$ ). Maximum value for  $V_{Diff-NOP1}$  selected so that bus termination power dissipation will be below 500 mW.

ECUs shall survive when a suppressed load dump pulse (ISO 7637-2, pulse 5b, positive voltage, maximum voltage modified see column "Maximum", line item " $V_{CAN\_H-NOP1-IC}$ ,  $V_{CAN\_L-NOP1-IC}$ " in Table 26) becomes coupled to CAN\_H and CAN\_L through a coupling capacitance of 1 nF each, at presence of transmit data input (TxD) patterns as will be generated by a regular CAN controller attempting to transmit messages (Table 27, line item TxD dominant duty cycle).



## 6.1.2 Unpowered Storage Temperature

The SAE J2284-5 electrical components within the ECU shall not suffer permanent damage if subjected to storage temperatures between  $-40$  and  $+150$  °C.

## 6.2 DC Operating Parameters

DC parameters shall be within the defined ranges for four unique conditions:

- a. Recessive Bus State, ECU disconnected from CAN Bus
- b. Dominant Bus State, ECU disconnected from CAN Bus
- c. Recessive Bus State, ECU connected to maximum CAN Bus
- d. Dominant Bus State, ECU connected to maximum CAN Bus

Compliance with the defined voltage ranges shall insure that ECUs will operate in a vehicle network application where a maximum DC offset between any two ECUs is present as stated in line item  $V_{\text{GND-OP}}$  in Table 1. Compliance shall be maintained over the following ECU operating ranges:

### ECU Operating Ambient Temperature

- a. High Temperature  $-40$  °C to  $+125$  °C
- b. Low Temperature  $-40$  °C to  $+85$  °C

### ECU Operating Parameters

**Table 10 – ECU Operating Parameters – CAN Data Communication**

Symbol	Minimum	Nominal	Maximum	Units	Conditions
$V_{\text{SUP1\_ECU}}$	7	12	16	Volts	(1)
$V_{\text{SUP2\_ECU}}$	6	12		Volts	(2)
$V_{\text{SUP3\_ECU}}$		12	18	Volts	(3)
$V_{\text{SUP4\_ECU}}$		12	26.5	Volts	(4)
$V_{\text{SUP5\_ECU}}$		12	34	Volts	(5)
$V_{\text{CAN\_H\_ECU-OP}}$ , $V_{\text{CAN\_L\_ECU-OP}}$	$-12$		12	Volts	(6)
$\Delta t_{\text{BIT\_ECU}}$	$-0.4$		0.4	%	(7)
$t_{\text{RSM\_ECU}}$			300	ms	(8)
ASIL rating	QM		B	--	(9)

1. Compliance (data communication) shall be maintained over said operating static ECU supply voltage range as measured at the ECU connector power/ground pins unless otherwise specified for a particular ECU or bus interface.
2. Selected ECUs shall support data communication functionality down to said voltage continuously.
3. Selected ECUs shall support data communication functionality up to said voltage for  $t = 60$  minutes.
4. Selected ECUs shall support data communication functionality up to said voltage for  $t = 60$  seconds.
5. Selected ECUs shall support data communication functionality up to said voltage for  $t = 400$  milliseconds.
6. Data communication operating common-mode bus input voltage range. Applies to recessive state and to dominant state.
7. Tolerance of length of a CAN bit time. Internal to the CAN controller. Including PLL effects. Tolerance value is applicable over operating conditions and aging, e.g., temperature, supply voltage and age drift, over specified ECU operating temperature, including ECU lifetime. Note, for some off-board tools, other standards might require a different tolerance range than this standard.
8. Maximum time after power disconnect for resuming regular data communication operation (capability to receive and transmit CAN messages) unless otherwise specified for a particular ECU. Time counts from the point in time when supply voltage enters operating supply voltage range specified for the particular ECU/particular bus interface. Upon return of power, the ECU shall resume regular data communication (ability to successfully receive messages and ability to attempt to transmit syntactically correct messages) without any operator intervention within said time.
9. Selected ECUs shall be capable to support an ASIL rating of up to B (ISO 26262) at one or more selected CAN bus interfaces.

## 6.2.1 DC Parameters – Output Behavior - Recessive Bus State - Bus Disconnected

DC bus output behavior of a single ECU (in the absence of other bus nodes) when transmitting a recessive bus state. Transmit data input (TxD) not asserted. (See Table 11.)

**Table 11 – ECU DC Parameters – Output Behavior Recessive - Bus Disconnected**

Symbol	Minimum	Nominal	Maximum	Units	Conditions
$V_{CAN\_H\_ECU-REC}$	2.0	2.5	3.0	Volts	no load <sup>(1)</sup>
$V_{CAN\_L\_ECU-REC}$	2.0	2.5	3.0	Volts	no load <sup>(1)</sup>
$V_{DIFF\_ECU\_OUT-REC}$	-500	0	50	Millivolts	no load <sup>(1)</sup>
$R_{DIFF\_ECU-REC-NZ}$	3.9		100	K $\Omega$	no load <sup>(2)</sup>
$R_{DIFF\_ECU-REC-RZ}$	118	125	132	$\Omega$	no load <sup>(3)</sup>
$R_{IN\_ECU-REC}$	5		50	K $\Omega$	no load <sup>(2)</sup>

- Bus bias functionality is on (active).
- Applies ECUs that do not contain a termination according to section 6.4. CAN transmit data input (TxD) not asserted. Applies over specified bus voltage ranges ( $V_{CAN\_H-OP}$ ,  $V_{CAN\_L-OP}$ ) stated in Table 10. Applies to powered state only.
- Applies to ECUs with built in termination according to section 6.4. CAN transmit data input (TxD) not asserted. Applies over specified bus voltage ranges ( $V_{CAN\_H-OP}$ ,  $V_{CAN\_L-OP}$ ) stated in Table 10. Split termination implementations are allowed with equal value 1% resistors. Minimum value 116.8  $\Omega$  when indicated so in a particular sourcing document.

## 6.2.2 DC Parameters – Output Behavior - Dominant Bus State - Bus Disconnected

DC bus output behavior of a single ECU (in the absence of other bus nodes) when transmitting a dominant bus state. Transmit data input (TxD) asserted. (See Table 12.)

**Table 12 – ECU DC Parameters – Output Behavior Dominant - Bus Disconnected**

Symbol	Minimum	Nominal	Maximum	Units	Conditions
$V_{CAN\_H\_ECU-DOM}$	2.75	3.5	4.5	Volts	(1)
$V_{CAN\_L\_ECU-DOM}$	0.5	1.5	2.25	Volts	(1)
$V_{SYM\_ECU}$	0.9	1.0	1.1	--	(2)
$V_{DIFF\_ECU\_OUT-DOM}$	1.5	2.0	3.0	Volts	(1)
$I_{CAN\_H\_ECU-DOM-SC}$			115	mA	(3)
$I_{CAN\_L\_ECU-DOM-SC}$			115	mA	(4)

- Resistive load  $50\ \Omega < R_L < 65\ \Omega$  connected between CAN\_H and CAN\_L. When termination present in an ECU then load 120  $\Omega$  connected between CAN\_H and CAN\_L.
- $V_{SYM} = (V_{CAN\_H} + V_{CAN\_L}) / V_{CC}$ , with  $V_{CC}$  being the supply voltage of the transmitter. Applies to dominant state and to recessive state and to transitions between the two states. Two times 30  $\Omega$  between CAN\_H and CAN\_L. Split termination concept with 4.7 nF center capacitance to ground. ECU attempts to transmit a message.
- Absolute output current value. CAN\_H connected to a fixed voltage (short-circuit).  $-3V < V_{CAN\_H} < +18V$ . ECU attempts to transmit messages. Selected ECUs may have to exhibit specified bus output currents at presence of a CAN\_H short-circuit (e.g. TxD dominant duty cycle according to Table 27) down to  $V_{CAN\_H} = -5V$  or  $-13V$ .
- Absolute output current value. CAN\_L connected to a fixed voltage (short-circuit).  $-13V < V_{CAN\_L} < +18V$ . ECU attempts to transmit messages (e.g. TxD dominant duty cycle according to Table 27).

## 6.2.3 DC Parameters – Output Behavior – ECU unpowered/Bus Bias Off - Bus Disconnected

DC bus output behavior of a single ECU (in the absence of other bus nodes) when ECU unpowered and/or when bus bias functionality is off (inactive). (See Table 13.)

**Table 13 – ECU DC Parameters – Input Behavior – ECU unpowered/Bus bias off – Bus Disconnected**

Symbol	Minimum	Nominal	Maximum	Units	Conditions
$I_{CAN\_H\_ECU\_LK}$ , $I_{CAN\_L\_ECU\_LK}$	-10		20	$\mu A$	(1)
1. All power supply inputs connected to 0V. CAN_H and CAN_L connected to +5V. Positive currents flow into the ECU.					

## 6.2.4 DC Parameters – Input Behavior – Bus Disconnected

DC bus input behavior of a single ECU in the absence of other bus nodes. (See Table 14.)

**Table 14 – ECU DC Parameters – Input Behavior - Bus Disconnected**

Symbol	Minimum	Nominal	Maximum	Units	Conditions
$V_{DIFF\_ECU\_IN-REC-RG}$	-3		0.5	Volts	(1)
$V_{DIFF\_ECU\_IN-REC-LP}$	-3		0.4	Volts	(2)
$V_{DIFF\_ECU\_IN-DOM-RG}$	0.9		8	Volts	(3)
$V_{DIFF\_ECU\_IN-DOM-LP}$	1.15		8	Volts	(4)
1. Bus interface not in sleep mode. Differential bus input voltage, bus disconnected. No time limit. ECU shall detect this as a recessive bus condition. 2. Bus interface in sleep mode. Differential bus input voltage, bus disconnected. No time limit. ECU shall detect this as a recessive bus condition. 3. Bus interface not in sleep mode. Bus bias is on and data receiver not in a low-power mode. Differential bus input voltage, bus disconnected. No time limit. ECU shall detect this as a dominant bus condition. 4. Bus interface in sleep mode. Differential bus input voltage, bus disconnected. No time limit. ECU shall detect this as a dominant bus condition.					

All line items in the Table 14 apply over operating bus voltage ranges ( $V_{CAN\_H-OP}$ ,  $V_{CAN\_L-OP}$ ) specified in Table 10.

## 6.2.5 AC Parameters – Output Behavior – Bus Disconnected

AC bus output behavior of a single ECU in the absence of other bus nodes. (See Table 15.)

**Table 15 – ECU AC Parameters – Output Behavior - Bus Disconnected**

Symbol	Minimum	Nominal	Maximum	Units	Conditions
$t_{DOM\_ECU}$	0.8		10	ms	(1)
1. Transmit data input (TxD) continuously asserted.					

## 6.2.6 DC Parameters - Recessive Bus State – Normal Operating Mode - Bus Connected

(See Table 16.)

**Table 16 – ECU DC Parameters – Recessive Bus State – Bus Connected**

Symbol	Minimum	Nominal	Maximum	Units	Conditions
$V_{CAN\_H\_ECU-REC}$		2.5	12.0	Volts	Reference ECU ground
$V_{CAN\_L\_ECU-REC}$	-12.0	2.5		Volts	Reference ECU ground
$V_{DIFF\_ECU\_OUT-REC}$	-120	0	12	Millivolts	$50 \Omega < R_L < 65 \Omega$

## 6.2.7 DC Parameters - Dominant Bus State – Normal Operating Mode - Bus Connected

(See Table 17.)

**Table 17 – ECU DC Parameters – Dominant Bus State – Bus Connected**

Symbol	Minimum	Nominal	Maximum	Units	Conditions
$V_{CAN\_H\_ECU-DOM}$		3.5	12.0	Volts	Reference ECU ground
$V_{CAN\_L\_ECU-REC}$	-12.0	1.5		Volts	Reference ECU ground
$V_{DIFF\_ECU\_OUT-DOM}$	1.5	2.0	3.0	Volts	$50 \Omega < R_L < 65 \Omega$

## 6.3 ECU Internal Capacitance

Capacitance of a single CAN bus interface in the absence of other bus nodes. (See Table 18.)

**Table 18 – ECU Internal Capacitance – ECU disconnected**

Symbol	Minimum	Nominal	Maximum	Units	Conditions
$C_{CAN\_H\_ECU}$			130	pF	f = 1 MHz
$C_{CAN\_L\_ECU}$			130	pF	f = 1 MHz
$C_{DIFF\_ECU}$			65	pF	f = 1 MHz

## 6.4 Termination

Bus terminations may be placed within ECUs. Terminations shall establish a defined resistance between the CAN\_H and CAN\_L wires. Each of two terminations in a network shall meet the requirements stated in Table 19. For location of terminations within a network, see 5.4.

**Table 19 – ECU Termination Characteristics**

Symbol	Minimum	Nominal	Maximum	Units	Conditions
$R_{Z\_ECU}$	see Table 11, $R_{DIFF\_ECU-REC-RZ}$		see Table 11, $R_{DIFF\_ECU-REC-RZ}$	$\Omega$	Each bus termination <sup>(1)</sup>
$R_{Z2\_ECU}$	59		66	$\Omega$	Split termination resistors <sup>(1)</sup>
$PWR_{RZ\_ECU}$	500			mW	For single resistor bus termination implementations <sup>(2)</sup>
1. Split termination implementations are allowed with equal value 1% resistors. Minimum value 58.4 $\Omega$ when indicated so in a particular sourcing document. 2. Over the entire operating ambient temperature range applicable to the position where the termination is located. Resistor power ratings need to be such that resistors will not be damaged when differential voltages stated in the two $V_{Diff}$ line items in Table 5 are applied to CAN_H and CAN_L. Note, when termination is implemented with split termination resistors, then the necessary resistor power rating will be less (e.g. half) than indicated above in line item $PWR_{RZ\_ECU}$ .					

Unless otherwise indicated in a particular sourcing document, ECUs shall package protect for implementation of split bus termination consisting of two equal value 1%, 400 mW resistors and one capacitor connecting from the termination center tap to ground. For terminating nodes, resistance  $R_{Z\_ECU}$  as measured between CAN\_H and CAN\_L shall always be present, including low power and loss of power modes.

## 6.5 Connector Parameters

Requirements for all connectors conveying the CAN signals are specified in Table 20.

**Table 20 – ECU Connector Characteristics**

Parameter	Symbol	Minimum	Nominal	Maximum	Units	Conditions
Current	$I_t$		40	300	mA	(1)
Contact Resistance	$R_t$		70	100	$m\Omega$	

1. Maximum value accommodates short-circuit current of two bus transceivers.

Connectors should have minimum length differences between CAN\_H and CAN\_L. Best practices for board layout should be followed to minimize differences in CAN\_H and CAN\_L trace lengths.

## 6.6 Bit Timing Requirements

Timing synchronization between ECUs shall be controlled by specification of the nominal (arbitration) bit time (inverse of bit rate), synchronization jump width, data sample point in the bit period, and the data sample mode. The bit period corresponds to the amount of time that a single NRZ data bit is logically driven onto the CAN bus. The data sample mode refers to the number of data samples taken within the bit period which are used to determine the NRZ data value on the CAN bus. The data sample point refers to the time period as measured from the start of the bit period to the point in the bit period where the NRZ data value is sampled. The synchronization jump width refers to the maximum amount of time by which a bit period may be shortened or lengthened to compensate for differences in bit periods and propagation delays between different ECUs on the network.

Tables 21, 22, and 23 specify timing requirements and briefly indicate the conditions which determine the minimum and maximum values required for SAE J2284-5 HSC implementation compliance.

### 6.6.1 Nominal Bit Time ( $t_{BIT}$ )

Compliance with the nominal (arbitration) bit time tolerance requirement is directly dependent on the system clock tolerance of the ECU and the programmed nominal bit time. In the typical CAN controller, the nominal bit time must be an integer multiple of the system clock periods. When the programmable nominal bit period is set to exactly 500 kbps, accuracy is only affected by the system clock tolerance. Otherwise, the accuracy is dependent upon both the deviation of the programmed bit period from nominal and the system clock tolerance. The contributions from drift or aging of the system clock source and contributions from inability to achieve the desired nominal bit time value are additive; the tolerance specification must be met after consideration of both.

### 6.6.2 Data Bit Time

Time quantum length shall be identical for nominal bit timing (arbitration bit rate) and for data bit timing (data bit rate used in CAN FD messages). For equations applying to data bit timing in CAN FD (BRS = recessive) messages see ISO 11898-1:2015(E).

### 6.6.3 Data Sample Mode

The data sampling shall always be set to single sample mode. Timing constraints to support 500 kbps communication over length of cable indicated in Table 2, line item ECU Distance eliminate the option of 2 out of 3 majority sampling.

### 6.6.4 CAN Bit Timing and Register Settings

Table 21 defines the CAN bit timing requirements. Coordinated bit timing settings are required to maintain synchronization between ECUs during both normal and error conditions.

**Table 21 – ECU CAN bit timing – min/max**

Term	Min	Nominal	Max
$t_{BIT(N)}$ <sup>(1)</sup>	1992 ns	2000 ns	2008 ns
$t_{BIT(D)}$ <sup>(2)</sup>	199.2 ns	200 ns	200.8 ns
$t_{BUS}$ <sup>(3)</sup>	—	—	<sup>(3)</sup>
$t_{LOGIC\_TX} + t_{LOGIC\_RX}$	10 ns		95 ns
$t_{TX} + t_{RX}$	40 ns		255 ns
$t_{ECU}$ <sup>(4)</sup>	50 ns	—	350 ns
$t_Q$ <sup>(5)</sup>	—	—	25 ns
$t_{SEG1}$	<sup>(6)</sup>	<sup>(6)</sup>	<sup>(6)</sup>

1. Bit time output from the CAN controller for message arbitration field when CAN FD format and for entire message when Classical CAN format used. The nominal bit time and the data bit time must be a programmable, integer multiple of the system clock periods. Minimum and maximum values correspond to a clock tolerance of  $\pm 0.4\%$ .
2. Bit time output from the CAN controller for message data field when CAN FD format used and BRS=R.
3.  $t_{BUS}$  one trip through bus wiring longest distance. Value specified in Table 1.
4.  $t_{ECU} = t_{LOGIC\_TX} + t_{LOGIC\_RX} + t_{TX} + t_{RX} + t_{CHK}$ .  $t_{LOGIC}$  reflects an interface delay between transceiver and microcontroller (includes microcontroller internal delay and PCB delay).
5. Time quantum length shall be identical in the message arbitration field and in the message data field.
6.  $t_{SEG1} = t_{BIT} - 1 (t_Q) - t_{SEG2}$

Tables 22 and 23 define compliant bit timing settings for the quanta which meet network assumptions outlined in Section 5.

**Table 22 – ECU CAN register settings for first standard time quanta**

Bit type	$N_Q$	$t_Q$	$\#t_Q t_{SJW}$	$\#t_Q t_{SEG2}$
(N)	80	25 ns	16	16
(D)	8	25 ns	2	2

**Table 23 – ECU CAN register settings for second standard time quanta**

Bit type	$N_Q$	$t_Q$	$\#t_Q t_{SJW}$	$\#t_Q t_{SEG2}$
(N)	160	12.5 ns	32	32
(D)	16	12.5 ns	4	4

$N_Q$  reflects the number of time quanta per bit. (N) denominates nominal (arbitration) bit timing settings. (D) denominates data (field) bit timing settings. Bit settings for time quanta in Tables 22 and 23 were calculated using Equations 6 to 8:

NOTE: All ECUs in a particular subnet need to use the same sample point positions in terms of percentage into the bit cell.

NOTE:  $t_{BIT(N)}$  is always set to 2000 ns. If the ECU is unable to be programmed to allow  $t_{BIT(N)}$  nominal to be equal to 2000 ns, the offset should be taken into account in the  $\Delta f$  term not the  $t_{BIT(N)}$  term.

$$t_{SJW} \geq \text{maximum of } \frac{20t_{BIT}\Delta f}{1 - \Delta f} \text{ or } \frac{\Delta f(20t_{BIT} - t_Q) + t_Q - t_{PROPmin}}{1 + \Delta f} \quad (\text{Eq. 6})$$

$$t_{SEG2min} \geq \text{maximum of } t_{SJW} \text{ or } 2t_Q \quad (\text{Eq. 7})$$

$$t_{SEG2max} \leq \text{minimum of } \frac{t_{BIT}(1 - 25\Delta f) - t_{PROPmax}}{1 - \Delta f} \text{ or } \frac{t_{BIT} - t_{PROPmax} - t_Q - \Delta f(25t_{BIT} - t_Q) + t_{PROPmin} / 2}{1 - \Delta f} \quad (\text{Eq. 8})$$

DEFINITION:  $\Delta f$  equals the maximum allowable deviation (either maximum or minimum) from the specified nominal bit rate divided by the specified nominal bit rate. See Tables 22 and 23 for specified values.

### 6.6.5 Transmitter Delay Compensation

Bus interfaces connecting to a subnet according to this standard shall perform (meaning shall support and enable) transmitter delay compensation functionality according to ISO 11898-1 :2015(E), unless otherwise indicated in a particular sourcing document.

### 6.7 Message Transmission and Reception

Unless otherwise indicated in a particular sourcing document, bus interfaces connecting to a subnet according to this standard shall be capable of receiving without losing messages and transmitting any of these message formats at any time in any sequence, interleaved in an arbitrary fashion:

- CAN FD format with 11 bit identifier length and with message data length of up to 64 bytes
- CAN FD format with 29 bit identifier length with message data length of up to 64 bytes
- Classical CAN format with 11 bit identifier length with message data length of up to 8 bytes
- Classical CAN format with 29 bit identifier length with message data length of up to 8 bytes

ECU becomes disconnected from power: ECU shall not disturb data communication between other ECUs, however if that ECU is in the process of transmitting, that single message may be truncated.

ECU experiences a reset: ECU shall not disturb data communication between other ECUs.

ECU becomes re-connected to power: ECU shall not disturb data communication between other ECUs, e.g. shall not cause error frames due to power re-apply. ECU shall resume data communication without any operator intervention.

When an ECU attempts to enter a low power mode, then the ECU shall enter the low power mode and shall remain in the low power mode until there is a valid wake-up condition. In other words, the ECU shall be capable to successfully enter the low power mode even when the bus is stuck in a dominant state.

ECUs that are in a low power condition shall not disturb data communication between other bus nodes.

ECUs shall behave consistent to the requirements stated in 5.6 (Communication/Survivability Under Faulted Conditions).

### 6.8 ECU Configuration Requirements

This section reflects configuration requirements for ECUs. ECUs shall comply with the content of Table 24, unless otherwise indicated for a particular ECU or CAN interface.

**Table 24 – ECU – Basic CAN Interface Functional Requirements**

Functionality	Functional Block	Active / Enabled	Inactive / Disabled
Protocol exception event on res bit detected recessive (Controllers shall not stop syntax or CRC checking for a message depending on bit values in that message)	Controller		X
Transmission of frames including bytes padded by the bus controller	Controller		X
Transmitter delay compensation for data bit timing	Controller	X	
Auto Bias	Transceiver	X	
CAN activity filter time, long	Transceiver	X	
Wake-up timeout	Transceiver	X	

## 6.9 ElectroMagnetic Compatibility (EMC)

The CAN physical layer, when incorporated into an ECU design, shall function as specified in the ECU's intended electromagnetic environment [CISPR 25, ISO 11451-2, and ISO 10605]. Additionally, the electromagnetic emissions produced during CAN related operation shall not interfere with the normal operation of other ECU's or subsystems.

Recommended testing includes:

- a. Radiated Immunity [ISO 11452-4 using the substitution method]
- b. Radiated Emissions [CISPR 25]
- c. Electrostatic Discharge (handling unpowered disconnected, powered connected) [ISO 10605]

Testing, using the SAE J2962-2 method, can be used to assess and/or compare the EMC performance of a CAN physical layer design(s).

Formal validation of the CAN physical layer design, however, shall occur during EMC testing of the actual ECU, using test procedures and acceptance criteria specified by the vehicle manufacturer.

## 7. CAN COMPONENT REQUIREMENTS

This section reflects selected recommended characteristics for integrated circuits (CAN semiconductor products) intended to support this standard. Unless otherwise indicated, parameter values in this section are measured at the pins of the particular integrated product (and not at the connector pins of an ECU).

### 7.1 Bus Transceiver Requirements

This section reflects selected recommended characteristics for CAN bus transceiver functionality intended to support this standard. Unless otherwise indicated, parameter values in this section are measured at the pins of the particular integrated product (and not at the connector pins of an ECU). Some parts of this section are labeled non-normative. Said content are present for reference only, because its source is ISO 11898-2 :2016(E).

The transceiver/SBC product data sheet shall state the following:

- CAN\_H (CAN\_L) output current maximum [mA] in regular operating mode (low power modes absent) when CAN\_H (CAN\_L) shorted to  $-3V < V_{CAN\_H/L} < +18V$  (reflects a network fault condition) when CAN transmit data input asserted (alternatively: A wider range than stated above).
- IC product supply current maximum [mA] in regular operating mode (low power modes absent) when both CAN outputs concurrently shorted to  $-3V < V_{CAN\_H/L} < +18V$  (reflects a network fault condition) when CAN transmit data input asserted (alternatively: A wider range than stated above).

NOTE: It would be sufficient to state what the physical layer functionality will consume excluding other outputs, such as supply voltage outputs, logic control outputs.

The transceiver shall meet the following requirements qualified as optional in ISO 11898-2, edition 2016.



**Table 25 – Bus Transceiver – Basic Requirements**

Feature / Characteristic	Mandatory	Optional	Not recommended
Consistent to ISO 11898-2, edition 2016	X		
Support of extended bus load range ( $45 \Omega < R_L < 70 \Omega$ )		X	
Transmit dominant timeout		X	
Bit timing requirements for data bit rates above 1 and up to 2 Mbps		X	
Bit timing requirements for data bit rates above 2 and up to 5 Mbps	X		
CAN activity filter time, long	X		
CAN activity filter time, short		X	
Wake-up timeout	X		
Extended maximum rating for CAN_H and CAN_L (+/-58V)		X	

NOTE: Transmit dominant timeout functionality is required for other parts of SAE J2284.

NOTE: When the short times in Table 25 are used it may be more difficult to pass required immunity testing when the transceiver is in low power mode and monitoring the bus for valid wake-ups.

The transceiver/SBC product shall not suffer damage when its CAN bus inputs are subjected to the voltages and durations stated in the Table 26. Successful transfer of messages between bus nodes is not expected (out of scope) when stated minimum or maximum voltages are present. (See Table 26.)

**Table 26 – Bus Transceiver – Maximum Bus Pin Voltage - No damage to transceiver (12 V system)**

Symbol	Minimum	Nominal	Maximum	Units	Conditions
$V_{CAN\_H-NOP1-IC}$ , $V_{CAN\_L-NOP1-IC}$	-27		40	Volts	(1)
$V_{CAN\_H-NOP2-IC}$ , $V_{CAN\_L-NOP2-IC}$	-15		+27	Volts	(2)
$V_{Diff-NOP-IC}$	-5		10	Volts	(3)
$V_{CAN\_H-ESD-IC}$ , $V_{CAN\_L-ESD-IC}$	See SAE J2962-2		See SAE J2962-2	Volts	(4)

1.  $t = 120$  s. Maximum and minimum static voltages without damage to the transceiver. Applies to transceiver powered and transceiver unpowered.
2.  $t = 120$  s. Transmit data pattern representative for CAN controller attempts to transmit messages (e.g. TxD dominant duty cycle according to Table 27). Termination resistance  $60 \Omega$ .
3.  $t = 120$  s.  $V_{Diff} = V_{CAN\_H} - V_{CAN\_L}$ . Preferred: No damage when  $V_{Diff} = +17V$  for 0.1 ms at  $V_{CAN\_H} = +18V$ , for 1000 pulses over IC product lifetime.
4. See SAE J2962-2 for details.

Minimum and maximum values in Table 26, line items  $V_{CAN\_H/L-NOP1-IC}$  and  $V_{Diff-NOP-IC}$  are non-normative.

The CAN physical layer (bus transceiver) shall comply with the EMC requirements as specified in SAE J2962-2.

The table below states general operating conditions for CAN transceiver/SBC products. (See Table 27.)

**Table 27 – Bus Transceiver – General Operating Conditions**

Symbol	Minimum	Nominal	Maximum	Units	Conditions
$V_{SUP}$	see Table 10		see Table 10	Volts	(1)
$V_{CAN\_H-OP}, V_{CAN\_L-OP}$	see Table 10		see Table 10	Volts	(2)
$V_{SYM\_IC}$	0.9	1.0	1.1	--	(3)
TxD dominant duty cycle	75			%	(4)

1. Table 10 contains information relevant for the specification of transceiver operating supply voltage ranges.  
2. Transceiver operating common-mode bus input voltage range. Applies to recessive state and to dominant state.  
3. Two times  $30\ \Omega$  between CAN\_H and CAN\_L. Split termination concept with 4.7 nF center capacitance to ground.  $V_{SYM} = (V_{CAN\_H} + V_{CAN\_L}) / V_{CC}$ , with  $V_{CC}$  being the supply voltage of the transmitter. Applies to dominant state and to recessive state and to transitions between the two states. 2.5 MHz square wave signal on TxD (5 Mbps).  
4. Transmit (TxD) dominant duty cycle without thermal shutdown for  $-40\ ^\circ\text{C} < T_{amb\_IC} < +105\ ^\circ\text{C}$  (ambient to the bus transceiver IC placed on a defined PCB). Repetitive TxD signal pattern of 2  $\mu\text{s}$  recessive followed by 6  $\mu\text{s}$  dominant.

Minimum/nominal/maximum values in line item  $V_{SYM\_IC}$  in Table 27 are non-normative.

**Table 28 – Bus Transceiver – DC Parameters – Output Behavior – Recessive/Off State**

Symbol	Minimum	Nominal	Maximum	Units	Conditions
$V_{DIFF-REC}$	-0.5		0.05	Volts	(1)
$V_{CAN\_H-REC}$	2.0	2.5	3.0	Volts	(1)
$V_{CAN\_L-REC}$	2.0	2.5	3.0	Volts	(1)
$R_{DIFF\_REC}$	12		100	$k\Omega$	(2)
$R_{CAN\_H}, R_{CAN\_L}$	6		50	$k\Omega$	(2)
$m_R$	-0.03		+0.03	--	(3)
$V_{DIFF-OFF}$	-0.2	0	0.2	Volts	(4)
$V_{CAN\_H-OFF}$	-0.1	0	0.1	Volts	(4)
$V_{CAN\_L-OFF}$	-0.1	0	0.1	Volts	(4)
$I_{CAN\_H\_LK}, I_{CAN\_L\_LK}$	-10		10	$\mu\text{A}$	(5)

1. No resistive load present ( $R_L > 10\ \text{M}\Omega$ ). Bus bias functionality is active (on).  
2. Over specified common-mode bus voltage ranges, see Table 10 ( $V_{CAN\_H-OP}, V_{CAN\_L-OP}$ ).  $R_{DIFF\_REC}$  line item corresponds to a recessive state input current range of 9  $\mu\text{A}$  to 75  $\mu\text{A}$  at a test voltage of  $V_{DIFF} = 0.9\text{V}$ . Applies to powered state only.  
3. Matching of the internal resistance.  
 $m_R = 2 * (R_{CAN\_H} - R_{CAN\_L}) / (R_{CAN\_H} + R_{CAN\_L})$ .  $0\text{V} < V_{CAN\_H} < +5\text{V}$ ,  $0\text{V} < V_{CAN\_L} < +5\text{V}$ .  
4. No resistive load present ( $R_L > 10\ \text{M}\Omega$ ). Bus bias functionality is inactive (off).  
5. Leakage current when unpowered. All supply inputs connected to ground. Both CAN inputs at 5V. Positive currents flow into the transceiver.

Minimum/nominal/maximum values in Table 28 are non-normative.

**Table 29 – Bus Transceiver – DC Parameters – Output Behavior – Dominant State**

Symbol	Minimum	Nominal	Maximum	Units	Conditions
$V_{Diff\_DOM1}$	1.5	2	3.0	Volts	(1)
$V_{CAN\_H-DOM}$	2.75	3.5	4.5	Volts	(2)
$V_{CAN\_L-DOM}$	0.5	1.5	2.25	Volts	(2)
$I_{CAN\_H\_SC1}$		60	115	mA	(3)
$I_{CAN\_H\_SC2}$			150	mA	(4)
$I_{CAN\_L\_SC1}$		60	115	mA	(5)
$I_{CAN\_L\_SC2}$			150	mA	(6)
1. $50\ \Omega < R_L < 65\ \Omega$ between CAN_H and CAN_L. Production test at $R_L = 60\ \Omega$ is sufficient. 2. $R_L = 60\ \Omega$ between CAN_H and CAN_L. 3. Absolute output current value. $-3V < V_{CAN\_H} < +27V$ . TxD dominant duty cycle as indicated in Table 27. Reflects a fault condition. 4. Optional functionality. Absolute output current value. $-15V < V_{CAN\_H} < -3V$ . TxD dominant duty cycle as indicated in Table 27. Reflects a fault condition. Preferred: 115 mA maximum. 5. Absolute output current value. $-15V < V_{CAN\_L} < +18V$ . TxD dominant duty cycle as indicated in Table 27. Reflects a fault condition. 6. Optional functionality. Absolute output current value. $+18V < V_{CAN\_L} < +27V$ . TxD dominant duty cycle as indicated in Table 27. Reflects a fault condition. Preferred: 115 mA maximum.					

Minimum/nominal/maximum values in Table 29 are non-normative, except of  $I_{CAN\_H\_SC2}$  and  $I_{CAN\_L\_SC2}$ . Table 29 applies over operating common-mode bus voltage ranges specified in Table 10 ( $V_{CAN\_H-OP}$ ,  $V_{CAN\_L-OP}$ ).

The bus transceiver shall be thermally self-protected and shall exhibit well-defined dominant state bus output current levels (maximum stated in the IC data sheet) at presence of bus short-circuit conditions or bad ground contact in a 12V-powered system where the combination of the transceiver and bus controller is capable of transmitting syntactically correct CAN messages.

**Table 30 – Bus Transceiver – DC Parameters – Input Behavior/Threshold – Sleep Mode Absent**

Symbol	Minimum	Nominal	Maximum	Units	Conditions
$V_{Diff\_RG\_TH}$	0.5	0.7	0.9	Volts	(1)
$V_{Diff\_RG\_HI}$			8	Volts	(2)
$V_{Diff\_RG\_LO}$	-3			Volts	(3)
1. Transceiver not in sleep mode. Bus bias functionality is on (active). 2. Transceiver not in sleep mode. Bus bias functionality is on (active). No time limit. Preferred (proposed for new designs): +9V maximum. 3. Transceiver not in sleep mode. Bus bias functionality is on (active). No time limit. Preferred (proposed for new designs): -4V minimum.					

Minimum/nominal/maximum values in Table 30 are non-normative. Table 30 applies over operating common-mode bus voltage ranges specified in Table 10 ( $V_{CAN\_H-OP}$ ,  $V_{CAN\_L-OP}$ ).

**Table 31 – Bus Transceiver – DC Parameters – Input Behavior/Threshold – Sleep Mode Present**

Symbol	Minimum	Nominal	Maximum	Units	Conditions
$V_{Diff\_LP\_TH}$	0.4	0.7	1.15	Volts	(1)
$V_{Diff\_LP\_HI}$			8	Volts	(2)
$V_{Diff\_LP\_LO}$	-3			Volts	(3)
1. Transceiver in sleep mode. Bus bias functionality is off (inactive). Ideally, 1.1V maximum. 2. Transceiver in sleep mode. Bus bias functionality is off (inactive). No time limit. Ideally, +9V maximum. 3. Transceiver in sleep mode. Bus bias functionality is off (inactive). No time limit. Ideally, -4V minimum.					

Minimum/nominal/maximum values in Table 31 are non-normative. Table 31 applies over operating common-mode bus voltage ranges specified in Table 10 ( $V_{CAN\_H-OP}$ ,  $V_{CAN\_L-OP}$ ).

The transceiver/SBC product shall support the AC parameters stated in Table 32 below.

**Table 32 – Bus Transceiver – AC Parameters**

Symbol	Minimum	Nominal	Maximum	Units	Conditions
$t_{LOOP-RG}$	0		255	ns	(1)
$t_{Bit(Bus)}$	155		210	ns	(2)
$t_{Bit(RXD)}$	120		220	ns	(3)
$\Delta t_{REC}$	-45		15	ns	(4)
$t_{Filter}$	0.5		5	$\mu$ s	(5)
$t_{Wake}$	0.8		10	ms	(6)
$t_{Bias}$	0		250	$\mu$ s	(7)
<ol style="list-style-type: none"> <li>1. Defined behavior is needed for <math>50 \Omega &lt; R_L &lt; 65 \Omega</math>, <math>C_L = 100</math> pF. Production test at <math>R_L = 60 \Omega</math>, <math>C_L = 100</math> pF, <math>C_{RXD} = 15</math> pF is sufficient. Specification item does not apply when transceiver in (some kind of) low power mode.</li> <li>2. Transmitted recessive bit width at 5 Mbps when there are five dominant bits followed by one recessive bit. <math>R_L</math>, <math>C_L</math>, and <math>C_{RXD}</math> see note 1 above.</li> <li>3. Received recessive bit width at 5 Mbps when there are five dominant bits followed by one recessive bit. <math>R_L</math>, <math>C_L</math>, and <math>C_{RXD}</math> see note 1 above.</li> <li>4. Receiver timing symmetry at 5 Mbps. <math>R_L</math>, <math>C_L</math>, and <math>C_{RXD}</math> see note 1 above.</li> <li>5. CAN activity filter time (long) for bus wake-up behavior. Bus dominant to receive output asserted when transceiver in lowest power mode and no bus messages present (CAN activity filter time, long).</li> <li>6. When there are dominant states on the bus and a bus wake-up could not be completed successfully, then transceiver shall reduce its power consumption after <math>t_{wake}</math> has expired.</li> <li>7. Time from bus bias activation criterion present to bus bias functionality on (active).</li> </ol>					

Minimum/nominal/maximum values in Table 32 are non-normative.

Bus transceivers should be capable to transmit and receive dominant and recessive states at differential loads between 45  $\Omega$  and 150  $\Omega$ .

## 7.2 Bus Controller Requirements

This section reflects selected recommended characteristics for CAN controllers intended to support this standard.

Bus controllers shall meet the following requirements qualified as optional in ISO 11898-1, edition 2015. Entries in column "Not recommended" mean functionality should not be used in a controller/ECU designed to meet the specification.

**Table 33 – CAN Controller – Basic Requirements**

Feature / Characteristic	Mandatory	Optional	Not recommended
Consistent to ISO 11898-1, edition 2015	X		
Ability to transmit and receive CAN FD frame format with data length of up to 64 bytes	X		
Ability to disable selected frame formats		X	
Disabling of protocol exception event on res bit detected recessive	X		
Ability to limit transmission to frames not containing bytes padded by the bus controller	X		
Limited LLC frames			X
MAC data consistency		X	
LLC Abort interface	X		
ESI and BRS bit values		X	
Handle		X	
PCS Status			X
FD_Transmit / FD_Receive message indication			X
Message time stamping	ECU-dependent		
Time base (subnet-wide common notion of time)	ECU-dependent		
Time base triggered message transmission			X
Disabling of automated retransmission attempts		X	
Limiting number of retransmission retries		X	
Bus monitoring mode	For tools	For ECUs	
Restricted operation mode		X	
Transmitter delay compensation for data bit timing	X		
Separate prescalers for nominal bits and for CAN FD data bits			X
Edge filtering during the bus integration state		X	
Time resolution for secondary sample point placement		X	

For a definition of terms used in Table 33, see chapters 3 and 4 in this document and see ISO 11898-1 :2015(E).

Bus controllers shall not stop syntax or CRC checking for a message depending on bit values in that message (in other words: The bus controller shall disable CAN protocol exception event handling).

Bus controllers shall perform bit resynchronization only on recessive to dominant signal edges.

Bus controllers shall support a bit timing parameter setting of Sync Jump Width (SJW) = 2 time quanta = PHASE\_SEG2.

Bus controllers shall support that both the arbitration bit time and the data bit time be integer multiples of the oscillator period that drives the CAN protocol controller (no change of time quanta length shall be needed within a CAN FD message).

Bus controllers shall support the entire range of base frame format message identifiers from 0 thru 2047 decimal without any exceptions.

Bus controllers shall support all numbers of data bytes in a message as specified in ISO 11898-1 :2015(E).

Bus controllers shall provide at least 2 (preferred: 3) transmit message buffers and 2 receive message buffers. Transmit buffers shall be able to be independently loaded.

Bus controllers shall support a minimum of one 64 byte transmit register and one 64 byte receive register.

Bus controllers shall be capable to automatically (e.g., without any CPU-support) transmit the message with the lowest CAN identifier first any time when more than one transmit buffer is armed for transmission.

If the bus controller supports multiple messages with the same CAN identifier then when two or more messages with the same CAN identifier are queued for transmission, bus controllers should transmit these messages in a first in, first out (FIFO) fashion, i.e., in the sequence in which they were queued.

Bus controllers shall support cancellation of a pending transmission (message awaiting access to bus) and should support notification to the host whether or not a transmit cancellation request was successful.

### 7.3 Microcontroller Requirements and Preferences

This section reflects selected recommended characteristics for microcontrollers with embedded CAN controllers intended to support this standard.

Unless otherwise indicated in a particular sourcing document, microcontrollers connecting to a subnet according to this standard shall be capable of receiving without losing messages and transmitting any of these message formats at any time in any sequence, interleaved in an arbitrary fashion:

- CAN FD format with 11 bit identifier length and with message data length of up to 64 bytes
- CAN FD format with 29 bit identifier length with message data length of up to 64 bytes
- Classical CAN format with 11 bit identifier length with message data length of up to 8 bytes
- Classical CAN format with 29 bit identifier length with message data length of up to 8 bytes

Some ECUs will have to be capable to support communication-network-wide accurate common notion of time. Consequently, unless otherwise indicated, microcontrollers intended to be used for this standard shall be capable of performing message time stamping and shall foresee hardware as needed to implement global time synchronization according to AUTOSAR release R4.2.2 or greater. Unless otherwise indicated, microcontrollers shall be capable to support a subnet-wide common notion of time where notion of time deviations between any two nodes are less than or equal to 1 ms.

Microcontrollers shall be designed such that they do not need to send Overload Frames on the bus.

Microcontrollers should have the ability to receive messages with any CAN identifier sent by other nodes even if the microcontroller transmits messages with that identical CAN identifier.

Microcontrollers shall be capable to enter low power modes when the receive data input is stuck dominant.

## 8. NOTES

### 8.1 Revision Indicator

A change bar (I) located in the left margin is for the convenience of the user in locating areas where technical revisions, not editorial changes, have been made to the previous issue of this document. An (R) symbol to the left of the document title indicates a complete revision of the document, including technical revisions. Change bars and (R) are not used in original publications, nor in documents that contain editorial changes only.